

YAMAHA



DIGITAL PROGRAMMABLE ALGORITHM SYNTHESIZER

Operating Manual

CONGRATULATIONS

Thank you for choosing the Yamaha DX9 Digital Programmable Algorithm Synthesizer. The DX9 employs unique and sophisticated FM digital tone generation technology combined with microcomputer control to permit creation of voices that are more "live" than voices available with any other system available.

We urge you to read this owner's manual thoroughly to ensure proper operation and maximum performance of the instrument.

Features

- The DX9 has a 20-voice internal memory, while external cassette tape can be used to store and load other voices. The DX9 is provided with a voice tape containing 120 pre-programmed voices.
- Extensive microcomputer programming control makes it possible to edit existing voices to change their character, or produce entirely new voices. New voices can also be created "from scratch."
- Edited or new voices can be stored either in the instrument's internal memory, or on an external cassette tape, so sounds you create can be saved for future use.

CONTENTS

PRECAUTIONS	1
DX9 OUTLINE	2
CONNECTIONS	4
PLAY MODE	5
FUNCTION MODE	6
FM TONE GENERATION	9
EDIT MODE	12
KEY TRANSPOSE	16
STORE / SAVE / LOAD	17
MIDI	21
LET'S ACTUALLY CREATE A VOICE	23
LFO BLOCKDIAGRAM	26
SPECIFICATIONS	27
VOICE DATA LIST	28

PRECAUTIONS

LOCATION

Avoid placing your synthesizer in direct sunlight or close to a source of heat. It is also important to avoid locations in which the instrument is likely to be subjected to vibration, excessive dust, cold or moisture.

HANDLING

Avoid applying excessive force to the instruments's knobs and switches.

POWER CORD

Always grip the power plug directly when unplugging. Removing the power plug from the wall socket by pulling on the power cord can result in damage to or shorting of the power cord.

Be sure to unplug your synthesizer if you will not be using it for an extended period of time.

RELOCATION

When moving the synthesizer once it has been set up, be sure to disconnect all cords that connect to other equipment. This will help prevent accidental damage to or shorting of interconnection cables.

CONNECTION

Carefully follow the "CONNECTION" instructions given in this manual when setting up your synthesizer.

Connection errors can lead to serious damage to the instrument, amplifier, and speakers.

CLEANING

Do not use solvents such as benzine or thinner to clean your synthesizer as these may cause discoloration or staining of the instrument's exterior. Use a soft, dry cloth.

SAVE THIS MANUAL

After studying this manual thoroughly, it should be stored in a safe place for future reference.

LIGHTNING

In the event of an electrical storm, the instrument's power cord should be unplugged to eliminate the possibility of serious damage.

OTHER APPLIANCES

Use your synthesizer where its digital circuitry cannot be influenced by electromagnetic radiation from appliances such as televisions, radios, etc.

DX9 OUTLINE

As stated in the feature summary on page 1, the DX9 can be used to play pre-programmed voices, pre-programmed voices can be edited to alter their character, or completely new voices can be created from scratch. Newly created voices can be memorized for future use.

To accomplish all this, the DX9 has four main operating modes:

- **PLAY-MEMORY SELECT Mode**

This is the normal performance mode, and the mode in which pre-programmed voices can be selected.

- **FUNCTION Mode**

This mode permits setting parameters pertaining to the effect of the controllers (thumbwheel, breath controller) and is also used for loading and saving data.

- **EDIT Mode**

This mode permits setting parameters that determine the character of the voices, and is used for editing existing voices or creating entirely new voices.

- **STORE Mode**

Edited or newly created voices can be programmed into the memory in this mode.

All functions of the DX9 are performed in one of the above modes. Proper understanding of the functions of each mode is the key to successful operation of and performance with the DX9.

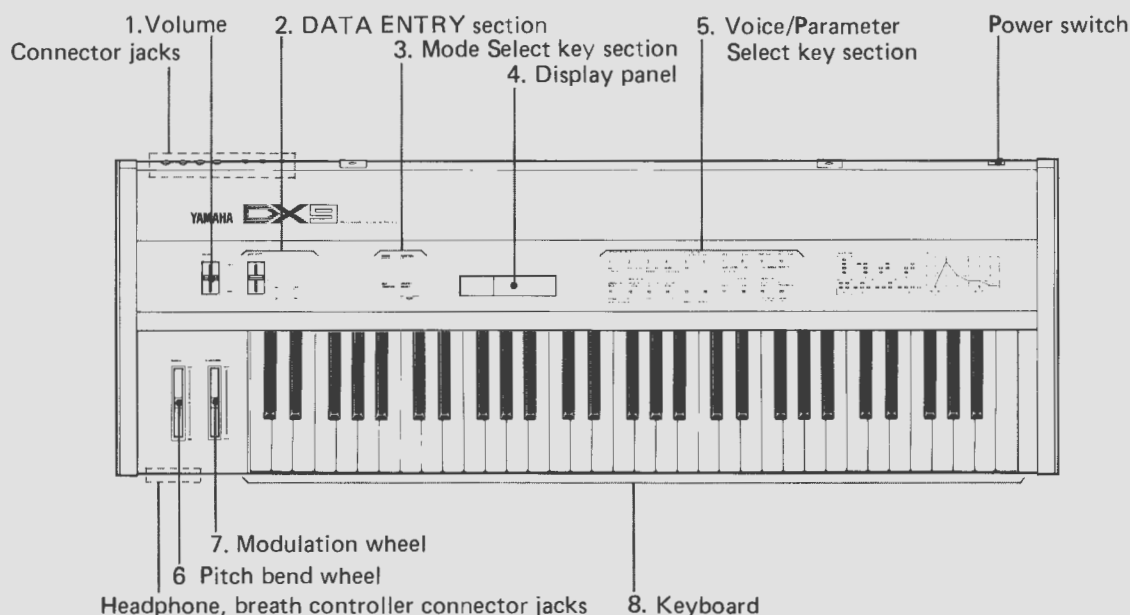

1 VOLUME

This controls the output level of the DX9 and at the same time controls the volume of the headphones.

2 DATA ENTRY

This combination of keys and linear control is used to enter and modify data.

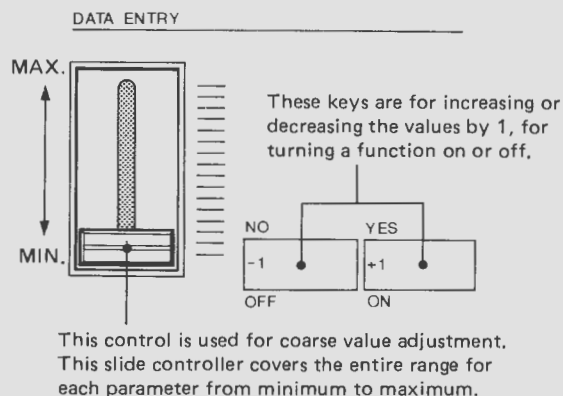

3 MODE SELECT KEY

Selects four operating modes of the DX9 (PLAY, EDIT, FUNCTION, STORE).

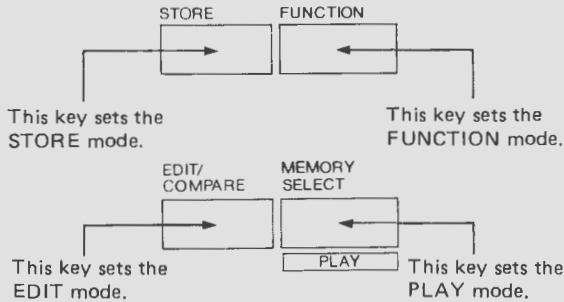

4 DISPLAY PANEL

This Liquid Crystal Display panel displays the parameters in each mode.



5 VOICE/PARAMETER SELECT KEY

These keys select the voices in the instrument's internal memory. The same keys are also used to select parameters in the FUNCTION or EDIT modes. One key can have a maximum of four different functions.

The function of these keys is determined by the Mode Select key.

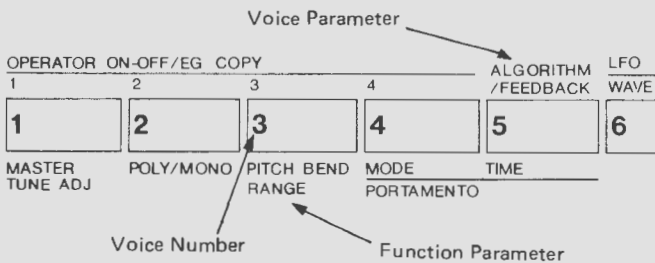

6 PITCH BEND WHEEL

The pitch bend range is set in the FUNCTION mode. The pitch bend wheel then permits upward and downward pitch bend throughout the set range.

7 MODULATION WHEEL

The modulation depth range is set in the FUNCTION mode. The modulation wheel then permits variation of modulation depth throughout the set range.

8 KEYBOARD

The DX9 has a 61-key keyboard with 16-voice polyphonic capability (a monophonic mode is also selectable).

• CASSETTE INTERFACE

An inexpensive cassette recorder can be connected to the cassette interface terminals, permitting saving and loading voices to and from standard compact cassette tapes. The DX9 is supplied with a voice cassette containing 120 voices in 6 groups of 20 voices each.

CONNECTIONS

● Setting Up and Applying Power

The DX9 does not have an internal power amplifier, therefore either headphones or an external amplifier/speaker system are required. A high-quality keyboard amplifier system is recommended.

Hook up your DX9 as shown in the diagram below.

Connections

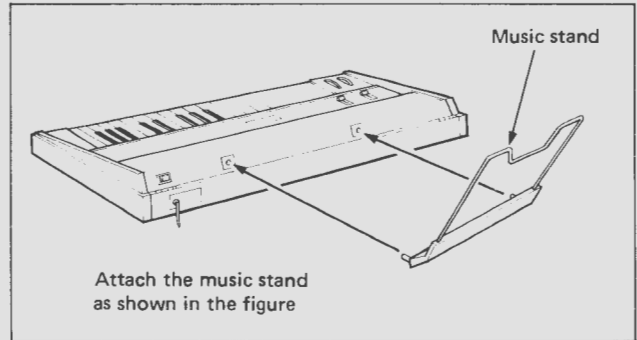
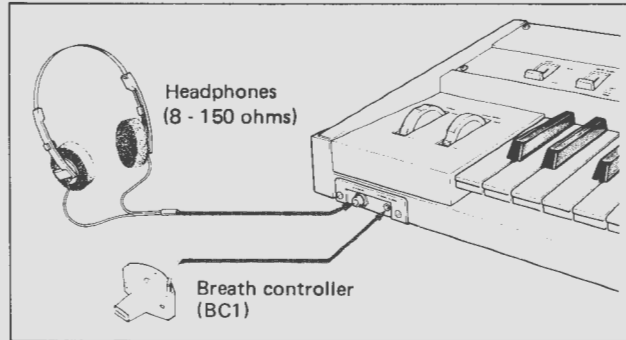
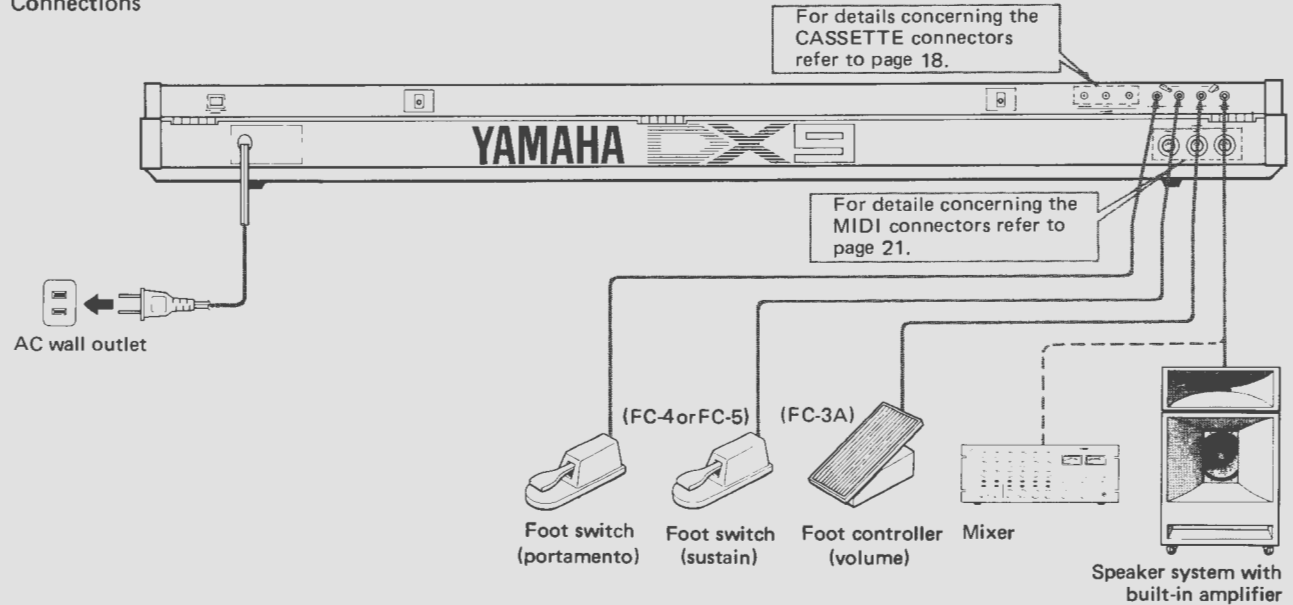

● Turn POWER ON

The DX9 power switch is located to the right of the rear panel (viewed from keyboard side). Turn the POWER switch ON only after all connections to other equipment (and to the AC supply) have been properly made. The display panel will appear as in the illustration below immediately after power is switched on.

After a few seconds, the same mode that was engaged before power was turned off is re-engaged. For example, if the PLAY mode was previously engaged, the PLAY mode will be re-engaged and the previously selected voice will be ready for performance. The same applies to the EDIT and FUNCTION modes.

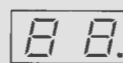
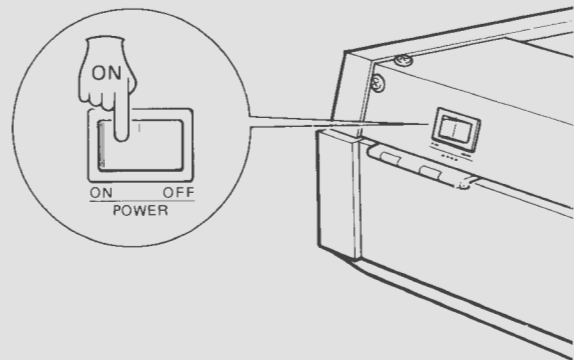

PLAY MODE

● Playing the Internal Voices

The DX9 has 20 internal voices, any one of which can be selected simply by pressing the **MEMORY SELECT** key, and then by pressing the appropriate Voice Select key. Each Voice Select key has a large numeral that corresponds to the voice number at its left edge.

Select and play each voice to get a feel for the kind of sounds that are available.

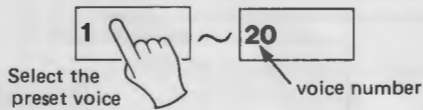
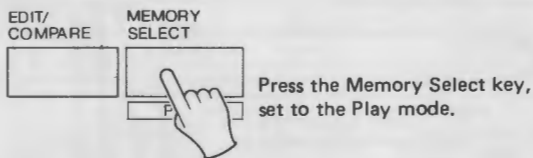

Display at the Play mode

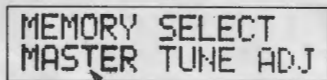

Display shows the last parameter at the Function mode.

● Set the desired VOLUME level

With power to the DX9 and your amplifier system ON, gradually raise the volume control while playing a note on the keyboard until the desired volume level is reached. Set the volume control on your amplifier so the optimum volume is attained with the DX9 volume control set at about "8"

● Playing the External Voices

The voice data contained on the voice data cassette must be loaded into the instrument before it can be played. Refer to the "LOAD" section on page 19 for loading instructions.

When data entry is initiated while in the PLAY mode, the parameter selected at the end of the FUNCTION mode can be controlled.

Fine adjustment of volume while playing can be achieved using an optional FC-3A foot controller plugged into the VOLUME jack on the DX9 rear panel. Remember that the DX9 and amplifier volume controls should be set high enough that adequate volume control range is available using the foot controller.

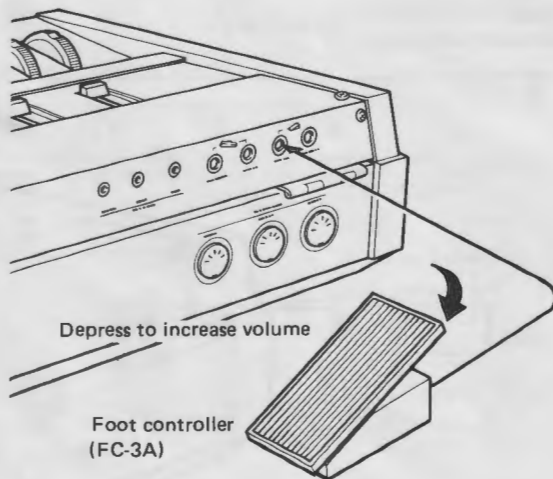

FUNCTION MODE

● FUNCTION Mode Applying Effects

The FUNCTION mode permits tuning, pitch bend, modulation, and application of other effects while playing, as well as voice data load/save operations.

Press the **FUNCTION** key to enter the FUNCTION mode. Setting controller range parameters, etc., is carried out using the DATA ENTRY controls.

- Function parameters are memorized and maintained even when power to the DX9 is cut off. Unlike voice data, however, function parameters cannot be saved in internal or external memory.

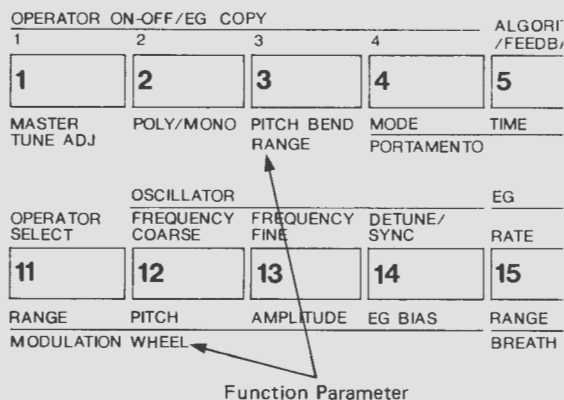

● MASTER TUNE

1

MASTER
TUNE ADJ

MASTER TUNE adjusts the overall tuning of the DX9 to match its pitch with other instruments. Pitch is variable over a 150 cent range. Press **MASTER TUNE** and then use the linear DATA ENTRY control for tuning.

DATA ENTRY

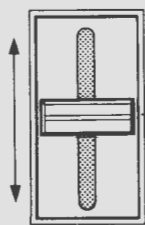

Only the linear control in the DATA ENTRY section functions for MASTER TUNE. Fine adjustments using the +1, -1 keys is not possible.

-1 +1

● POLY/MONO

2

POLY/MONO

Determines whether the DX9 will function in the polyphonic or monophonic mode. Press the DATA ENTRY **-1** key for polyphonic operation, and the **+1** key for monophonic operation.

- The range of the portamento effect is different in the polyphonic and monophonic modes. Refer to the PORTAMENTO section below.

● PITCH BEND RANGE

3

PITCH BEND
RANGE

The range of pitch bend can be set from 0 to 12. 0 range is equivalent to no pitch bend. A setting of 12 permits pitch bend over a ± 1200 cent (2 octave) range. If the range is set at 7, then pitch bend will be possible over a ± 700 cent range (i.e. plus or minus one fifth).

Pitch bend wheel

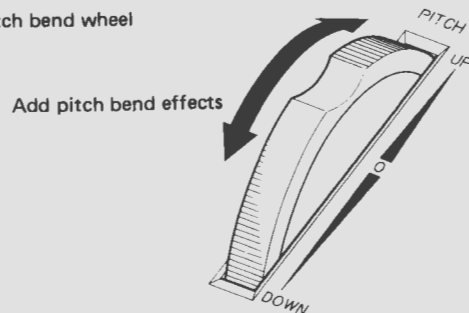

● PORTAMENTO

4 **5**

MODE TIME
PORTAMENTO

The portamento effect varies according to whether the DX9 is in the polyphonic or monophonic mode.

MONOPHONIC MODE:

In this mode press the DATA ENTRY **+1** key to activate "FINGERED PORTA". In this mode the legato effect is applied only when a second note is played while a previously played note is still held.

Press the DATA ENTRY **-1** key to activate "FULL TIME PORTA". In this mode portamento is always applied.

POLYPHONIC MODE:

In the polyphonic mode "FULL TIME PORTA" is always activated.

TIME:

Adjusts the speed of the portamento effect from 0 to 99. A 0 setting results in no effect, while a setting of 99 produces the longest (slowest) portamento.

- The portamento effect can also be turned ON or OFF using an optional FC-4 or FC-5 foot pedal once the portamento function has been turned on in the "FULL TIME PORTA" mode. Pressing the foot pedal turns the effect ON. The effect is OFF when the foot pedal is released.
The portamento effect cannot be turned ON or OFF in the "FINGERED PORTA" mode.
- An FC-4 or FC-5 foot pedal can also be connected for sustain pedal control. In the monophonic mode, a key pressed while another key is held will take priority, and the sustain effect will apply to the new key. Releasing the pedal turns the sustain effect OFF.

• **CASSETTE**

7	8	9	10
SAVE/VERIFY	LOAD	LOAD SINGLE	REMOTE
CASSETTE			

These keys permit saving all 20 internal memory voices to an external cassette tape, or loading 20 voices or a specified single voice from an external cassette tape. SAVE/VERIFY, LOAD, LOAD SINGLE, and REMOTE keys are provided. Refer to the STORE/SAVE/LOAD instructions on page 17.

SAVE/VERIFY:

The SAVE function saves all 20 voices in the internal memory to an external cassette tape, while the VERIFY function checks to make sure that all the voices were properly saved.

Pressing the **SAVE/VERIFY** key repeatedly alternates between the "SAVE TO TAPE?" and "VERIFY TAPE?" displays.

LOAD:

This key permits loading 20 voices at a time from an external cassette tape into the internal memory.

LOAD SINGLE:

This key permits loading a specified single voice from a group of voices previously saved on a cassette tape. The number of the voice in the group from which the desired voice will be loaded must be specified (1 – 20).

REMOTE:

This key permits remote control of cassette recorders that have a REMOTE terminal. Normally when the cassette recorder's remote terminal is connected to the DX9, the tape will not run until either the LOAD or SAVE function is initiated even if the Play or Record controls are engaged. The REMOTE function makes it possible to start or stop the tape to facilitate locating the beginning of voice groups, etc.

• **MODULATION WHEEL / BREATH CONTROLLER**

11	12	13	14
RANGE	PITCH	AMPLITUDE	EG BIAS
MODULATION WHEEL			
15	16	17	18
RANGE	PITCH	AMPLITUDE	EG BIAS
BREATH CONTROL			

The modulation wheel or breath controller can be used to control LFO modulation depth applied to pitch, amplitude or envelope producing controllable tremolo or vibrato effects while playing. Setting the RANGE, PITCH, AMPLITUDE and ENVELOPE GENERATOR BIAS parameters for each controller is basically the same process, so we'll concentrate mainly on the MODULATION wheel. Since LFO modulation is the effect in question, the voice used must have non-zero set for PITCH and/or AMPLITUDE MODULATION SENSITIVITY parameters in the EDIT mode. Refer to the MODULATION SENSITIVITY section on page 13 for details.

1. MODULATION WHEEL

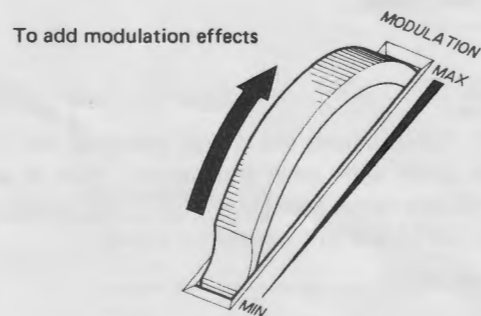

RANGE:

Range can be set from 0 to 99. No effect is produced with a 0 setting, and a setting of 99 produces maximum effect.

PITCH:

Determines whether LFO modulation is applied to pitch. Pitch is modulated if ON, and not modulated if OFF.

AMPLITUDE:

Determines whether LFO modulation is applied to amplitude. Amplitude is modulated if ON, and not modulated if OFF.

EG (ENVELOPE GENERATOR) BIAS:

When EG BIAS is ON, volume or brilliance (wow) variation effects can be added with the controllers by varying the level of each operator's envelope generator. MOD. SENSITIVITY (AMPLITUDE) is used to set the sensitivity (refer to page 13.)

Applying EG BIAS to a modulator results in brilliance effects, while applied to a carrier it results in volume variation effects. In some cases, if the carrier sensitivity is maximum and the controller is set to its minimum, no sound will be produced.

As for "modulator" and "carrier", refer to the FM TONE GENERATION section on page 9.

2. BREATH CONTROL

The LFO modulation effect programmed can be controlled using an optional BC1 breath controller. The effect is controlled by blowing into the BC1 mouthpiece. The effect will not be audible unless breath is applied to the controller.

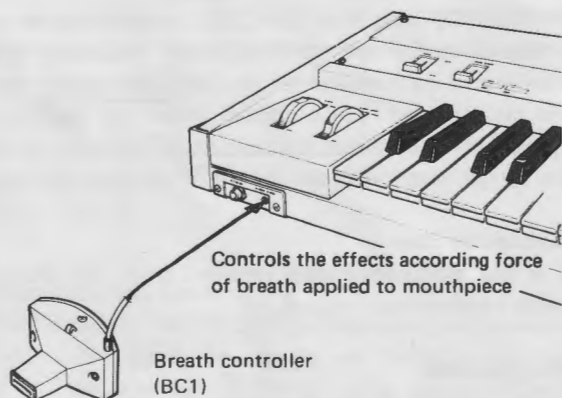

• EDIT RECALL / VOICE INIT

Pressing this key alternately switches to EDIT RECALL and VOICE INIT.

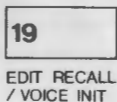

EDIT RECALL:

This function makes it possible to recall a voice that was previously being edited or created.

If, for example, the PLAY mode is accidentally or purposely entered while editing, the voice that was being edited can be recalled with this function.

If the **EDIT RECALL** key is pressed, the display shows "EDIT RECALL?". Pressing the DATA ENTRY **YES** key then causes the "ARE YOU SURE?" display. Verify by pressing the **YES** key again, and the voice previously being edited will be restored.

VOICE INIT (Voice Initialize):

This function sets up the basic voice data for creating new voices. Press the **VOICE INIT** key and the display panel will read "VOICE INIT?". Press the **YES** key and the DX9 will respond with "ARE YOU SURE?" Verify by pressing the **YES** key second time. This sets up the basic voice data and activates the DX9 EDIT mode.

• BATTERY CHECK

A backup battery power supply is built into the DX9 so that voice data will be maintained even when power to the instrument is off. The state of the backup system can be checked by pressing the **EDIT RECALL/VOICE INIT** key. The operational battery voltage range is from 2.2 volts to 3.3 volts. If the backup battery voltage drops below 2.2 volts, replacement of the backup system is necessary. The backup system consists of special batteries which can be replaced only by a Yamaha dealer. Contact your nearest Yamaha dealer when replacement becomes necessary.

• MEMORY PROTECT

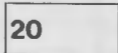

MEMORY PROTECT

The DX9's internal MEMORY PROTECTION function will prevent any accidental erasure of the internal voice data. You will first have to turn the MEMORY PROTECT OFF in order to STORE or LOAD the voice data. Also, do not forget to turn the MEMORY PROTECT function back ON after storing or loading operation. (Please refer to page 17)

FM TONE GENERATION

FM Tone Generation . . . Understanding the Basics

The DX9 is an entirely new type of synthesizer employing an entirely new FM digital tone generation system. This unique Yamaha system permits finer control over subtle musical nuances and vastly expanded voice creation potential compared to conventional synthesizers.

1. The Meaning of FM

FM stands for Frequency Modulation. FM radio broadcasts use the same principle. One signal—the modulator—modulates a second signal—the carrier.

In FM radio the carrier is an extremely high "ratio" frequency and the modulator is the music signal to be broadcast. In effect, the carrier "carries" the modulator signal through the atmosphere to your receiving antenna.

FM broadcasting

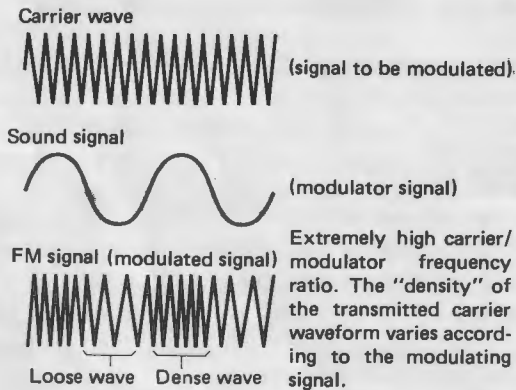

The FM tone generator system is similar in principle, but in this case both the carrier and modulator are audible signals, and their frequencies can be almost equal.

FM tone generation

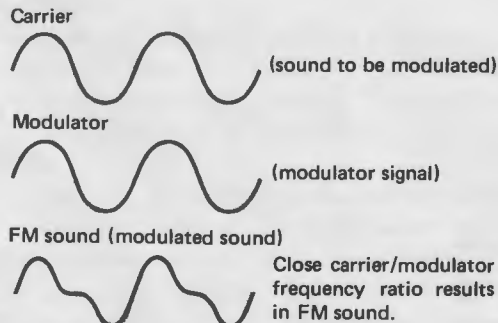

2. FM Tone Generation In the DX9

In the DX9, the carrier signal determines the pitch of the note produced and modulator determines the shape of the waveform produced and therefore its timbre. This explanation may make it look like the carrier and modulator are two entirely separate things. In fact, they are one and the same. A special oscillator unit called an "operator" can be used as either a carrier or modulator in the DX9.

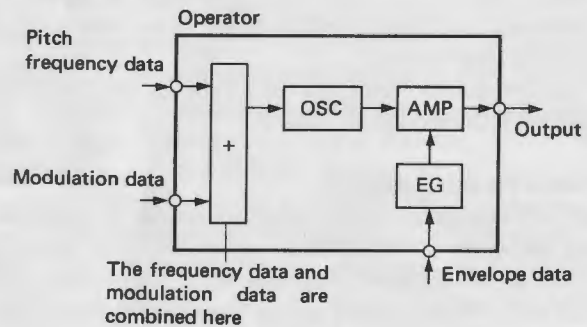

1) Pitch Frequency Data

Pitch frequency data from the DX9's microcomputer system determines the operator's oscillation frequency. When the operator is used as a carrier, this frequency is equivalent to the pitch of the note produced. When the operator is being used as a modulator, the ratio of its frequency to that of the carrier determines the timbre of the note produced.

2) Modulation Data

This is the modulation data received from the previous operator's (modulator) output.

3) Envelope Data

When the operator is used as a carrier the envelope data determines the volume envelope of the note produced. When the operator is used as a modulator the envelope data determines the timbre envelope of the note produced.

For example, the pitch frequency data applied to an operator used as a carrier determines the frequency of the sine wave output from the operator. Inputting envelope data results in an output waveform similar to that shown in the figure.

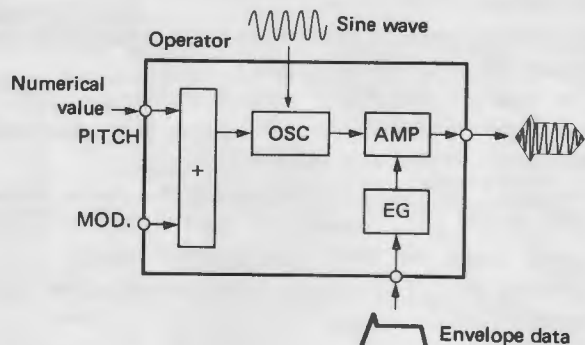

• **Basic Operator Functions**

1) **Relationship of Carrier and Modulator**

An operator can be used as either a carrier or modulator. These two basic operator functions are the basis for the FM tone generation system. Two operators can be combined in two different ways.

1. **Modulator and carrier combinations**

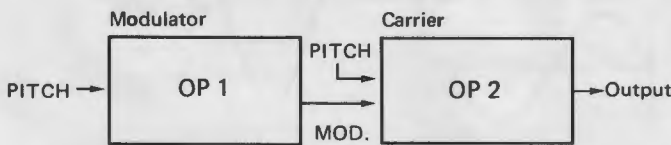

2. **Carrier and carrier combinations**

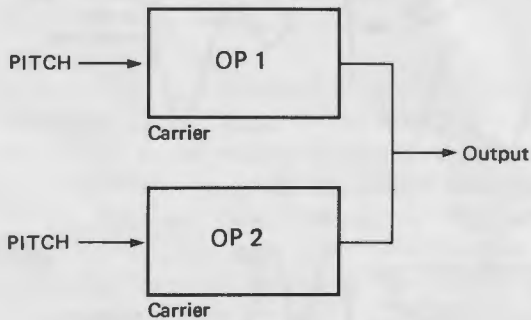

2) **Carrier and Carrier**

This configuration results in a pure sine wave output from both operators. The combination of these waveforms can sound much like a conventional organ.

• **Carrier and carrier combinations**

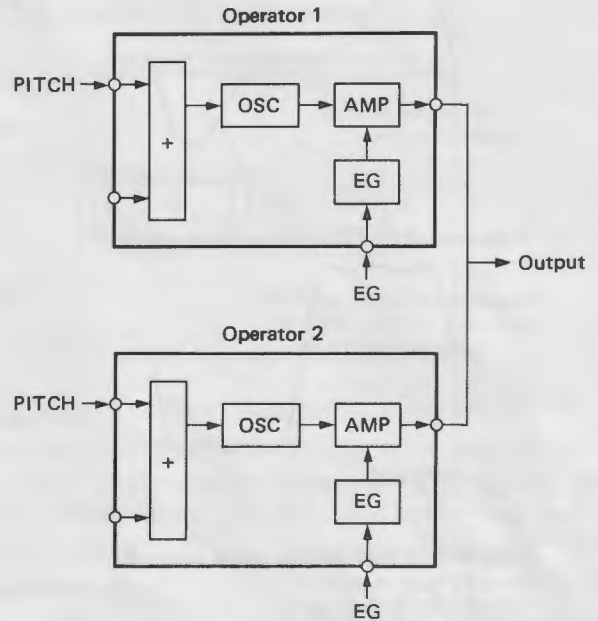

3) **Modulator and Carrier**

In the modulator/carrier configuration using two operators, shown in the figure, the operator on the left is the modulator and the operator on the right is the carrier. In the FM system, the last operator in a chain of two or more oper-

ators is the carrier. By varying the ratio of the modulator and carrier frequencies, and by varying the envelope of the modulator, an extremely broad range of highly complex waveforms (complex harmonic structure) can be created.

• **Modulator and carrier combinations**

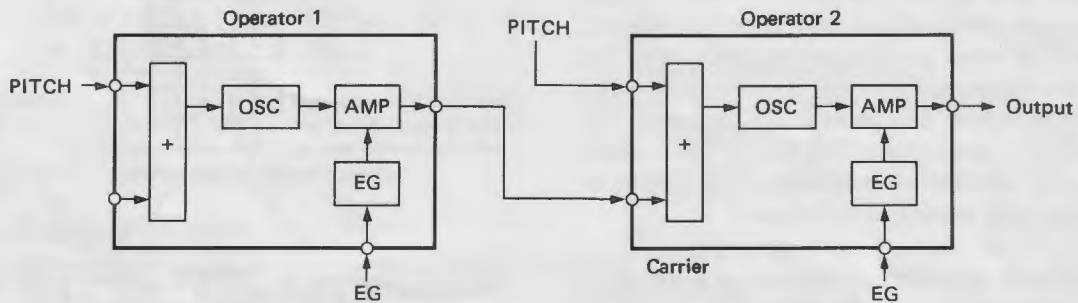

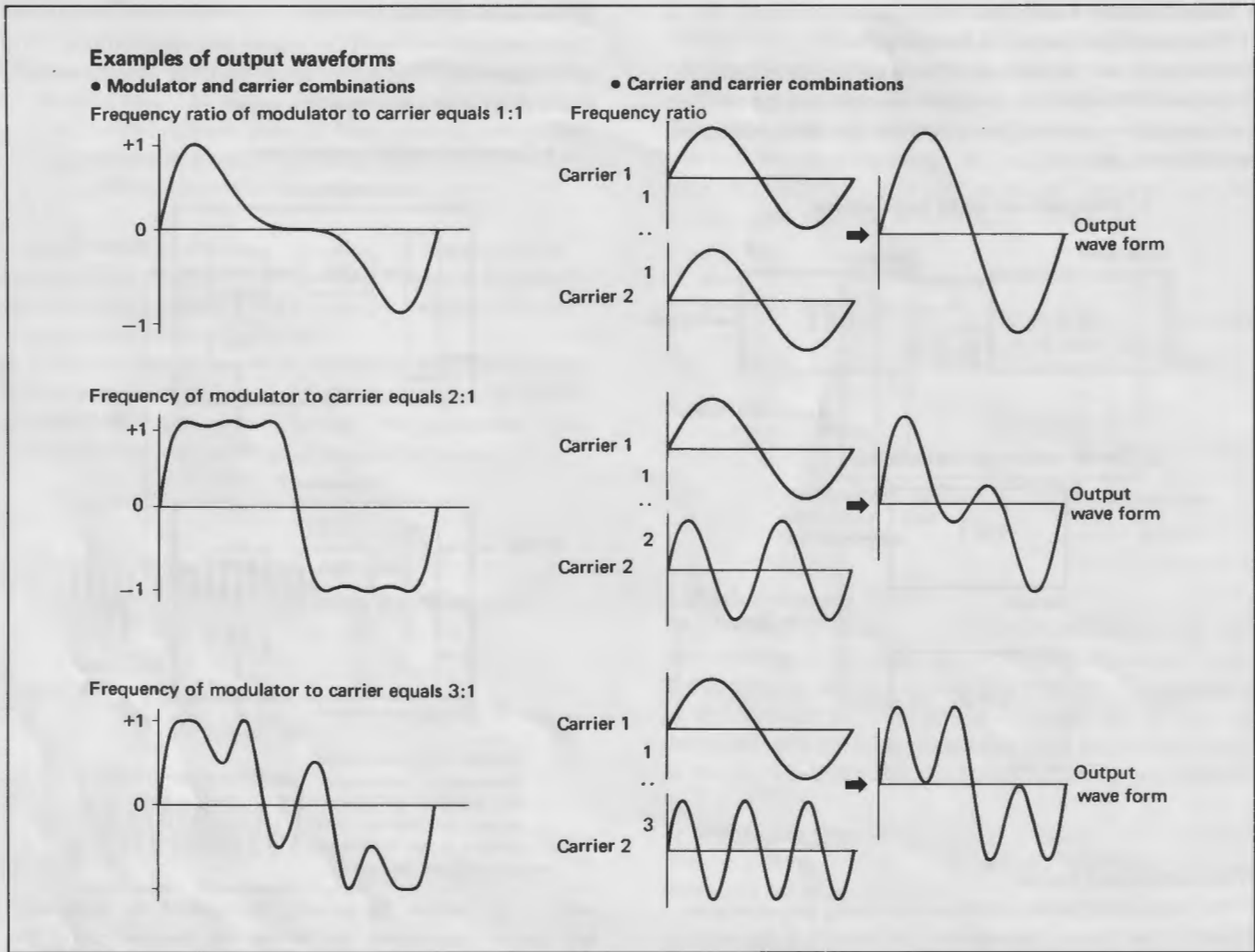

3. Algorithms Combining Several Operators

The DX9 has a total of four operators. The way in which these operators are combined is known as an "algorithm." The DX9 has 8 different pre-programmed algorithms. The 8 algorithms are displayed graphically on the control panel. Taking algorithm number 5 as an example, the lowest two operators—1 and 3—are carriers. The two operators above the carriers will function as modulators. The output of operator 4 is fed back (feedback) to its input.

The above is a brief description of the internal workings of the FM tone generator system. By varying the pitch frequency, modulation and envelope data it is possible to edit pre-programmed voices or to create entirely new voices.

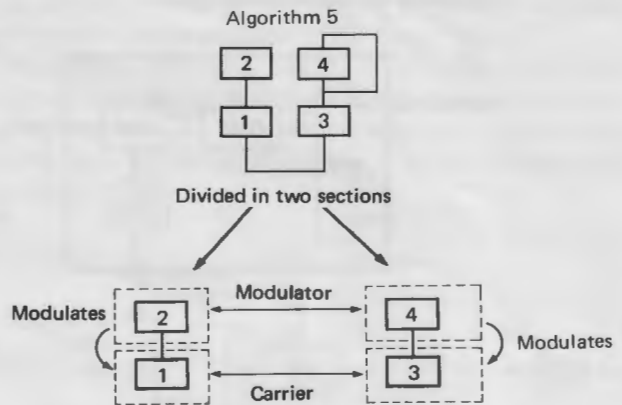

EDIT MODE

• EDIT MODE Creating Voices

The EDIT mode can be used to edit pre-programmed voices or to create entirely new voices. Press the **EDIT/COMPARE** function key to enter the EDIT mode.

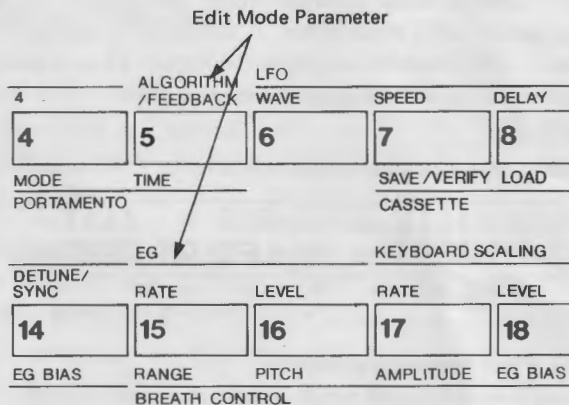

Setting and modifying parameters is carried out using the DATA ENTRY controls just as in the FUNCTION mode. A small dot will appear next to the voice number in the display if any data is modified. The original voice can be recalled at any time while editing by pressing the **EDIT/COMPARE** key again. The voice number will flash indicating that you are hearing the original voice. To continue editing press the **EDIT/COMPARE** button again. Now for an explanation of the DX9's functions and operation.

• The indicators display for EDIT mode

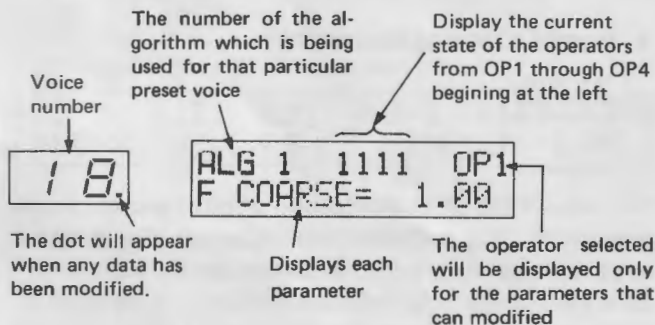

• OPERATOR ON-OFF/EG COPY

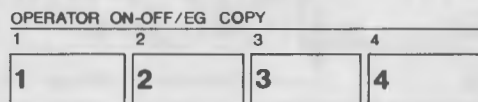

In the EDIT mode these keys permit turning any of the operators on or off, and copying the EG data of any operator to any other operator (EG COPY).

OPERATOR ON-OFF:

Pressing keys **1** through **4** will result in the corresponding operator being turned OFF, indicated by a "0" in the appropriate location on the display panel (the group of four 1's and/or 0's corresponds to operators 1 through 4). Press the key again to turn the operator back on-indicated by a "1" on the display.

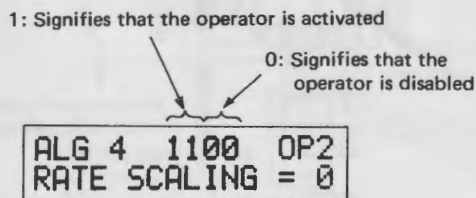

- No sound will be produced if the carrier operators have all been disabled.

EG COPY:

This function copies the EG data from one operator to another. While holding the selector **STORE** key, press the number of the operator from which you want to copy EG data.

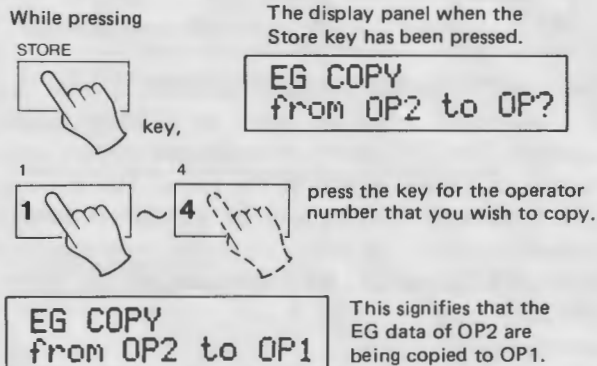

• ALGORITHM / FEEDBACK

Pressing this key alternately switches to ALGORITHM and FEEDBACK.

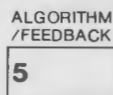

ALGORITHM:

This key permits selection of one of the 8 algorithms. Press the DATA ENTRY **+1** key to increment (advance) the number of the selected algorithm, and the **-1** key to decrement the algorithm number. The slide control can be used for larger variations.

This value will change.

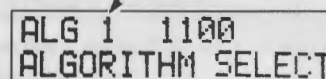

FEEDBACK:

One operator in each of the 8 algorithms has its output fed back to its input. This is the feedback operator. The amount of feedback applied can be adjusted over a range of 0 to 7. By increasing the FEEDBACK level the harmonics are increased, resulting in the generation of noise-like sounds.

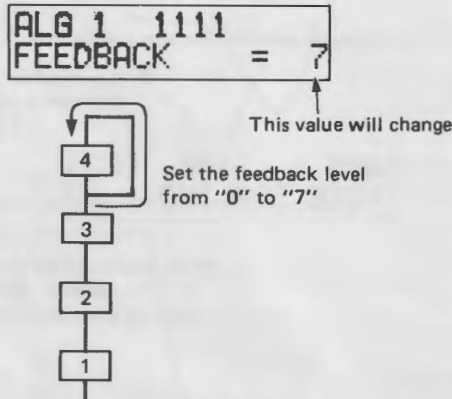

• **LFO**







LFO			
WAVE	SPEED	DELAY	PMD/AMD
6	7	8	9

The Low Frequency Oscillator produces low-frequency sine, saw-tooth or square waves, or a SAMPLE/HOLD waveform. The LFO waveform can be used to apply vibrato, tremolo or "wow" effects to the voices. The amount of LFO modulation applied can be controlled using the modulation wheel, or breath controller once appropriate WAVE, SPEED and DELAY parameters are set. (Refer to page 26)

WAVE:

This selects the waveform output by the LFO. Any of the six waveforms shown below can be selected.



- TRIANGL :  (Triangular wave)
- SAW DWN :  (Number 1 sawtooth waveform)
- SAW UP :  (Number 2 sawtooth waveform)
- SQUARE :  Square wave
- SINE :  Sine wave
- S/HOLD :  Sample and hold

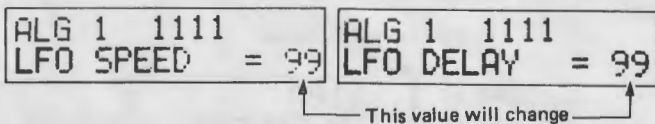

SPEED:

The speed (frequency) of the LFO can be set from 0 to 99. 0 is the slowest LFO speed while 99 is the fastest.

DELAY:

This creates a delay between initial key closure and application of LFO modulation. A setting of 0 results in no delay – LFO modulation begins the instant a key is pressed – and a setting of 99 creates the longest delay.

PMD/AMD:

Pressing this key alternately switches to PMD and AMD.

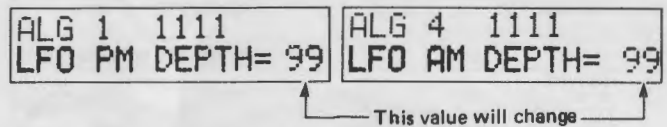

PMD (Pitch Modulation Depth):

Varies, over a 0 to 99 range, the depth of LFO modulation applied to pitch. A 0 setting produces no pitch modulation, and a setting of 99 produces maximum modulation.

The PMD function is separate from the effect of the controllers, and can be used to apply vibrato effects that are entirely independent of the controller settings.

AMD (Amplitude Modulation Depth):

Varies, over a 0 to 99 range, the depth of LFO modulation applied to amplitude. A 0 setting produces no amplitude modulation, and a setting of 99 produces maximum modulation.

The AMD function is separate from the effect of the controllers, and can be used to apply tremolo effects that are entirely independent of the controller settings.

• **MODULATION SENSITIVITY**

MOD SENS. PITCH/ AMP
10

This adjusts the sensitivity (depth) of pitch and amplitude modulation. This parameter must be greater than 0 before any amplitude or pitch modulation can be applied.

Be sure to check this parameter before using the modulation wheel or other controllers.

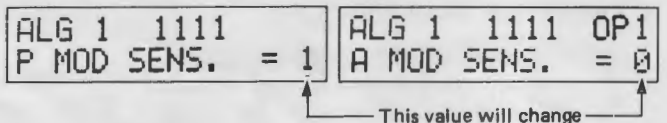

PITCH:

Sensitivity to pitch modulation is variable from 0 to 7. This value sets the modulation sensitivity for all operators. Applying pitch modulation results in vibrato type effects.

AMPLITUDE:

Sensitivity to amplitude modulation is variable from 0 to 3. Amplitude modulation sensitivity is set independently for each operator. Applying amplitude modulation to a modulator creates "wow" effects, while applied to a carrier it results in tremolo effects.

Operators are selected using the **OPERATOR SELECT** key. Pressing the **OPERATOR SELECT** key successively selects the operators in order from 1 to 4. The number of the selected operator is displayed in the upper right hand corner of the display panel. Operators that are turned OFF will be "skipped" and the number of the next active operator will be displayed.

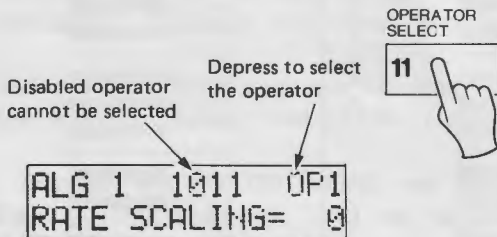

OSCILLATOR

OSCILLATOR		
FREQUENCY COARSE	FREQUENCY FINE	DETUNE/ SYNC
12	13	14

These keys set the pitch data for each operator.

ALG 1 1111 OP1 F COARSE= 1.00 ALG 1 1111 OP1 F FINE = 1.00

↑ This value will change ↑

FREQUENCY COARSE/FREQUENCY FINE:

The oscillation frequency of each oscillator is set using the **FREQUENCY COARSE** and **FREQUENCY FINE** keys. With a value of 1.00 as standard (8 feet), the **FREQUENCY COARSE** control can be used to set the frequency between 0.5 and 32 times. The **FREQUENCY FINE** control then permits fine frequency adjustment between 1 and 1.99 times.

DETUNE / SYNC:

Pressing this key alternately switches to DETUNE and SYNC.

ALG 1 1111 OP1 OSC DETUNE = 7 ALG 1 1111 OSC KEY SYNC:OFF

↑ This value will change ↑ This display will change

DETUNE:

The operator frequencies as determined by the **FREQUENCY COARSE** and **FREQUENCY FINE** controls can be detuned over a -7 to +7 range.

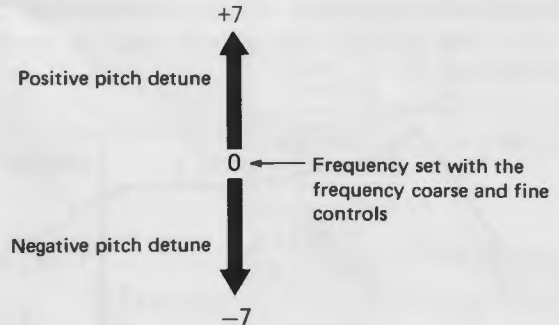

SYNC (Synchronize):

When the SYNC function is ON, all operators begin oscillation from the same phase angle (0 degrees). With SYNC OFF the phase angle at which an operator begins oscillation is carried over smoothly from the preceding note. In the polyphonic mode, for example, maximum simultaneous output is 16 notes. If a 17th key is pressed the first note makes a smooth transition to the 17th note.

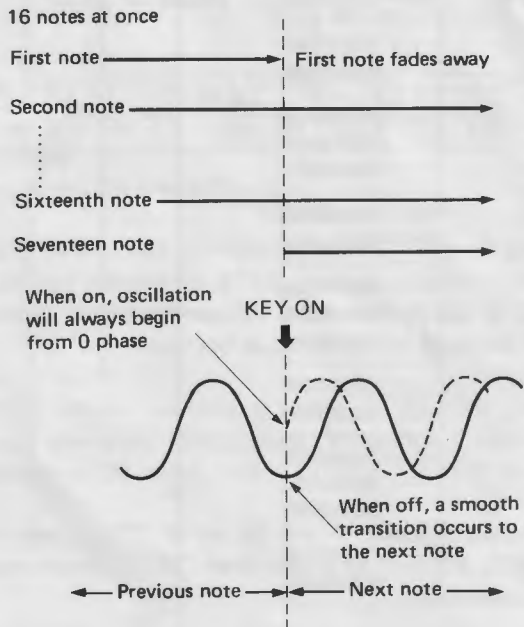

EG (Envelope Generator)

EG	
RATE	LEVEL
15	16

The envelope generator determines how the amplitude (volume) or timbre (tone) of a note will vary over time. Envelope modulation of a modulator results in time-based timbre variations, while envelope modulation of a carrier produces amplitude variations.

The parameters which determine the "shape" of the envelope are RATE 1 through RATE 4 and LEVEL 1 through LEVEL 4. The RATE parameters determine how long it takes the envelope to reach one LEVEL from another. The envelope applied to each operator can be set individually, permitting an essentially infinite range of envelope combinations.

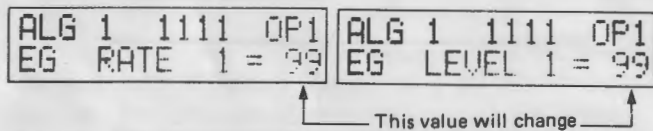
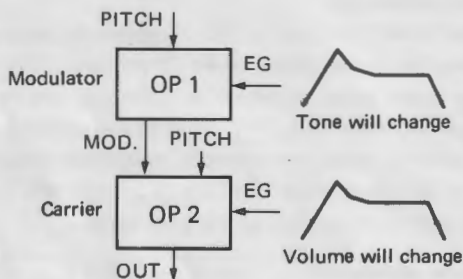
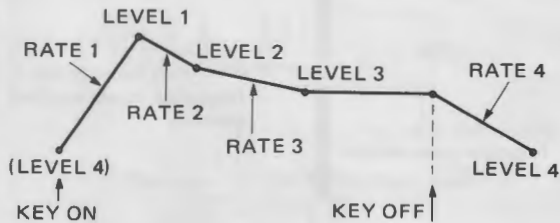

RATE:

Pressing the **[RATE]** key successively selects RATE parameters 1 through 4. Each RATE parameters can be set from 0 to 99. A 0 setting produces the longest (slowest) RATE, and a 99 setting produces the fastest RATE.

LEVEL:

Pressing the **[LEVEL]** key successively selects LEVEL parameters 1 through 4. Each LEVEL parameter can be set from 0 to 99. 0 is no output, while 99 is maximum level.

- Normally LEVEL 4 will be set at "0". In this case LEVEL 1 should be greater than "50" to ensure proper EG operation.

• **KEYBOARD SCALING**

KEYBOARD SCALING

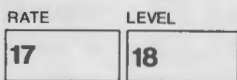

The EG RATE and LEVEL parameters can be varied as the frequency of the notes increases.

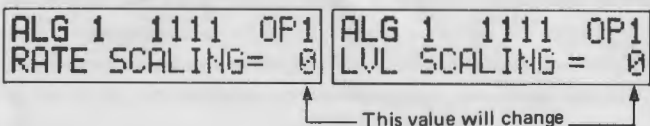

RATE:

The EG RATE of each operator can be set to get shorter as the frequency of the notes increases -- similar to a piano. RATE can be set from 0 to 7.

LEVEL:

The EG LEVEL of each operator can be set to decrease as the frequency of the notes increases. LEVEL can be set from 0 to 99.

• **OPERATOR**

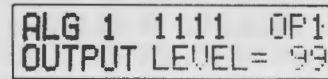
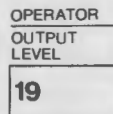

This value will change ↑

Permits setting the output level of each operator.

OUTPUT LEVEL:

Controls overall EG level, like the EG DEPTH controls in conventional synthesizers. OUTPUT LEVEL can be set between 0 and 99.

For example, if a specific operator is found to be unnecessary once a voice has been created, its output level can be set to 0.

- Since the OPERATOR ON-OFF function operates only in the EDIT mode and OPERATOR ON-OFF data is not stored in memory, the OUTPUT LEVEL of all unnecessary operators should be set to 0.

In order to maintain constant overall output level even when changing algorithms, the output level of all the carrier operators have been preset to a suitable value.

• **KEY TRANPOSE**

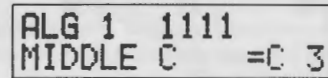
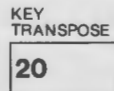

This value will change ↑

Transposes pitch over a ±1 octave range in semitone steps with C3 as standard. Press the **[KEY TRANPOSE]**, and then the keyboard key corresponding to the desired amount of transposition according to the illustration on page 16. To transpose up one octave, for example, press the **[KEY TRANPOSE]** key and then press C4 on the keyboard.

KEY TRANSPOSE

● KEY TRANSPOSE

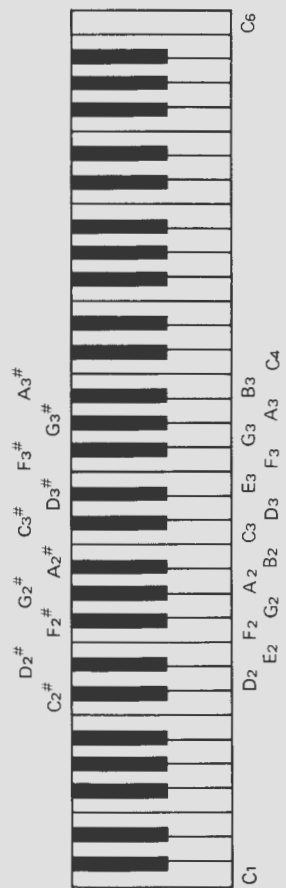

C1 through C2 are all C2
 Press the key that you wish to transpose.
 C4 through C6 are all C4

You can transpose in semitones for -1 octave
 You can transpose in semitones for +1 octave

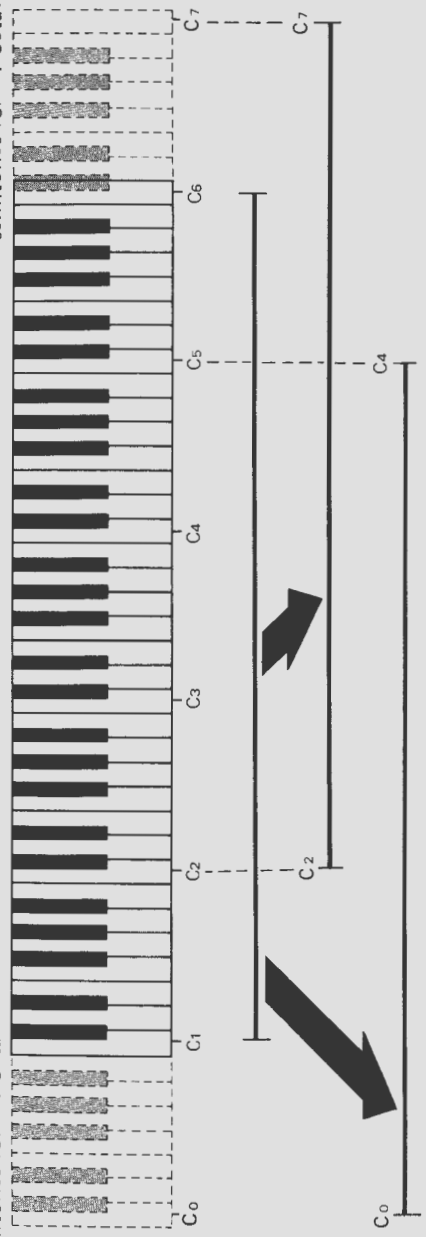

* For example, when transposing up 1 octave

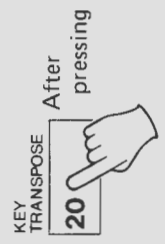

The display when transposing up 1 octave

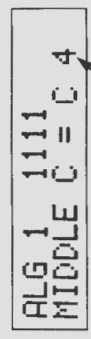

Display shows "C4"

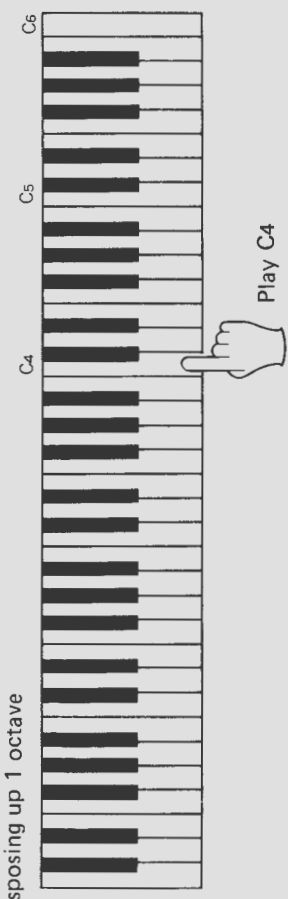

STORE /SAVE /LOAD

STORE/SAVE/LOAD

The DX9 used the following functions to move voice data from one location to another:

1. STORE

Stores a voice being edited in the "edit buffer" into one of the preset memory locations.

2. SAVE

Saves all 20 voices from the internal memory onto an external cassette tape.

3. LOAD

Loads a entire block of 20 voices or a single voice from external cassette tape into the internal memory.

• SAVE/LOAD Cautions

Note the following points when loading voices from the supplied voice tape or when saving or verifying newly created voices onto a tape:

- 1) The supplied voice data cassette tape (master tape) contains the same data on both sides A and B. However, the method in which the recordings were made differs between sides A and B to provide compatibility with all types of cassette tape recorders. If an error occurs during a LOAD operation, and if adjusting the level (volume) fails to correct the error, reverse the cassette tape and LOAD the data from side B. This should correct the problem.
- 2) During a SAVE or LOAD operation, don't pick the tape recorder up and move it, and don't subject it to a shock of any kind. Be careful not to touch the connections either, since doing so may cause an error.
- 3) Always use the same cassette recorder when handling DX9 data. Using a different tape recorder may make LOAD operations difficult to execute.
- 4) It's a good idea to make a backup copy of the master voice data cassette tape, and always use your backup copies for day to day operations. That way, if your tape is damaged in any way, you can always make another new backup copy from the master. Refer to the section on loading data. When making a backup copy, LOAD the data from the master tape into the DX9 memory, group by group. Then, put a fresh tape in the cassette recorder and read the data back onto the new tape with the SAVE command.
- 5) Before you SAVE voice data onto a cassette tape, index the tape by making a microphone recording of the information you need prior to the start of voice data recording on the tape.
- 6) It's not possible to copy voice data from one tape to another by dubbing the tape between cassette recorders. Always LOAD the data into the DX9 memory first, then SAVE it on a fresh cassette tape.

1. MEMORY PROTECT

When voices are loaded from external cassette tape or edited voices are stored in memory, the previous voice is erased. Turning the MEMORY PROTECT function ON makes it impossible to accidentally erase voice data. MEMORY PROTECT must be turned OFF in order to carry out any LOAD or STORE operation. MEMORY PROTECT is automatically turned ON whenever the instrument's power switch is turned ON. Always be sure to turn the MEMORY PROTECT function back ON after loading or storing voices.

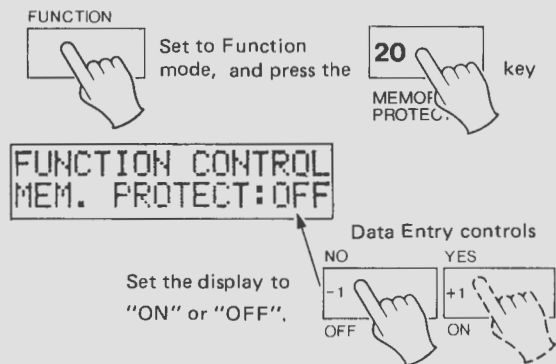

2. STORE

Voices that have been edited or entirely new voices are not automatically programmed into one of the internal memory locations. Voices are edited and created in a buffer, and must be STORED in one of the memory locations for use.

- 1) Turn MEMORY PROTECT OFF.
- 2) Press MEMORY SELECT, then hold the STORE key and press the preset key to which you want to program the new voice.

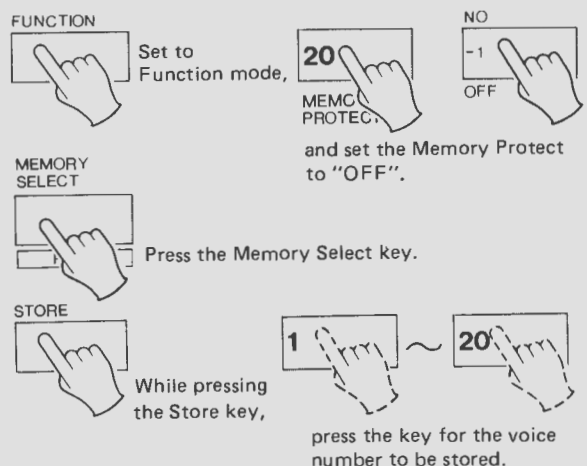

When a voice is STORED in this manner, the voice data that was previously in that memory location is erased, so be sure that you either have a copy of the voice on tape or don't need the voice before erasing it with a STORE operation. Be sure to turn MEMORY PROTECT back on after the STORE OPERATION.

● **Connecting a Cassette Recorder**

Connect the cassette recorder to the DX9 using the supplied connection cable as follows:

Connections

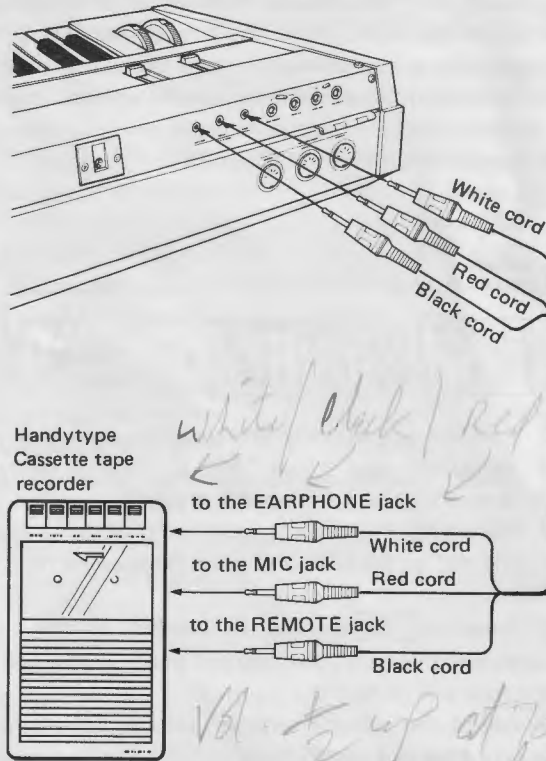

- 1) Connect the DX9 "IN" terminal and the cassette recorder's "EARPHONE" or "HEADPHONE" jack with the white cord.
- 2) Connect the DX9 "OUT" terminal and the cassette recorder's "MIC" jack with the red cord.
- 3) Connect the DX9 "REMOTE" terminal and the cassette recorder's "REMOTE" terminal with the black cord. (No connection required for cassette recorders that do not have a REMOTE terminal)

3. SAVE

The SAVE functions saves all 20 voices in the internal memory to an external cassette tape.

- 1) Make sure the cassette recorder is connected properly and load the cassette tape to which you wish to SAVE the DX9's internal voices.
- 2) Enter the FUNCTION mode and set the display to read "SAVE TO TAPE?" using the **SAVE/VERIFY** key.
- 3) Press the **YES** key and the display will read "from MEM to TAPE all ready?". Press the **YES** key again and the "ready" portion of the display will disappear and the SAVE operation will begin.

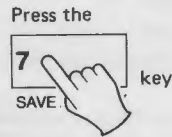

FUNCTION CONTROL
SAVE TO TAPE ?

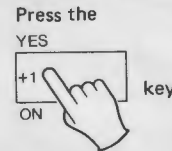

from MEM to TAPE
all ready?

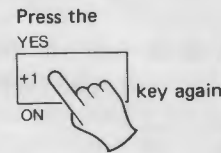

from MEM to TAPE
all

The "ready" portion will disappear and Save operation will begin.

- 4) After a brief pause a number "1" will appear in place of "ready" indicating that the first voice is being saved. Each voice is indicated as it is saved (1-20). When the SAVE operation is completed, the display will read "VERIFY TAPE ready?".

4. VERIFY

The VERIFY function checks to make sure that all the voices were properly saved on external cassette tape by a SAVE operation. It is advisable to always use the VERIFY function after saving a group of voices to prevent accidental loss of voices due to improper connections or other faults during the SAVE process. Also, be sure to VERIFY the same group of voices that were saved or an ERROR message will result.

- 1) Set the cassette tape to the beginning of the voice group to be verified.
- 2) Make sure that the cassette recorder headphone jack is properly connected to the DX9.
- 3) Press the cassette recorder PLAY button, then press the DX9 **YES** key. The tape will begin to play and a pilot tone will be heard.

- 4) Adjust the cassette recorder volume control so that the pilot tone is at a comfortable listening level.

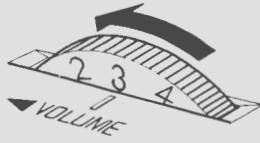

- 5) When the data signal begins (a discontinuous tone) the bottom right hand corner of the display should read "1" through "20" as each voice is verified. When verification is complete the display will read "OK" followed by "VERIFY COMPLETED".

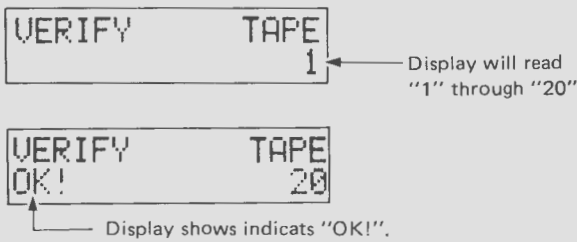

The VERIFY operation can be carried out directly (not necessarily immediately following a SAVE operation) by using the **SAVE/VERIFY** key to set the display to "VERIFY TAPE?" in the FUNCTION mode.

● **REMOTE**

Normally when the cassette recorder's remote terminal is connected to the DX9 with the FUNCTION CONTROL TAPE REMOTE OFF, the tape will not run until either the LOAD or SAVE function is initiated even if the Play or Record controls are engaged. The REMOTE function makes it possible to start or stop the tape to facilitate locating the beginning of voice groups, etc.

- 1) Press the **REMOTE** key.



- 2) Press the **ON** key.



This turns remote control ON so the tape recorder can be run as required.

5. LOAD

Two types of LOAD functions are provided: LOAD, with which an entire group of 20 voices is loaded, and LOAD SINGLE, with which any desired single voice can be loaded.

1) **LOADing an entire 20-voice group.**

- (1) Make sure the cassette recorder is properly connected to the DX9, insert the cassette containing the desired voice group, and set the tape to the beginning of that voice group (disengage the remote control function to do this). Stop the cassette recorder.
- (2) Turn MEMORY PROTECT OFF.

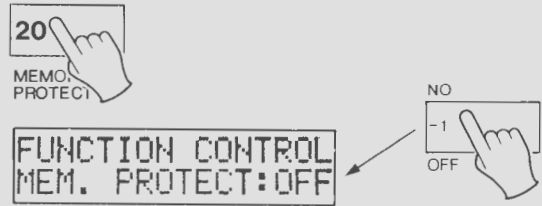

- (3) Press the **LOAD** key and then the **YES** key and the display will read "from TAPE to MEM all ready?" (the remote control function is re-engaged).
- (4) Make sure the cassette recorder's headphone jack is connected to the DX9 and press the cassette recorder PLAY button.
- (5) Press the **YES** key and the "ready?" portion of the display will disappear, the tape will begin to run, and the pilot tone will be heard.
- (6) Adjust the cassette recorder volume control to set the pilot tone at a comfortable listening level.

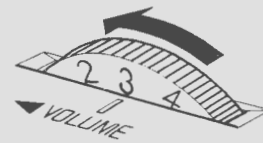

- (7) When the data signal begins the bottom right hand corner of the display will read "1" through "20" as the corresponding voices are loaded into the internal memory.

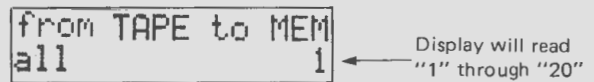

- (8) When the LOAD operation is completed the DX9 PLAY mode will be engaged and the cassette recorder will stop.

● **Using a Cassette Recorder with No REMOTE Terminal**

The SAVE and LOAD procedures are basically same for cassette recorders with or without a REMOTE terminal. When there is no REMOTE terminal, the cassette recorder must manually be set to the record or play mode after the **SAVE** or **LOAD** and **YES** keys have been pressed ("ready?" display).

● **If an ERROR message is displayed during LOAD or VERIFY**

If this happens the tape will stop. Rewind the cassette tape to the beginning of the voice group, adjust the level (volume) on your tape recorder, and repeat the LOAD operation.

Simply increasing or decreasing the output level of your cassette recorder should correct the error, but it may take a few tries to find the appropriate level.

If this does not correct the problem, the cause may be one of the following:

VERIFY ERROR

- 1) The voices were not properly saved to excessive speed fluctuation in your cassette recorder.
- 2) Improper record level (this applies to recorders that have a record level control).

LOAD ERROR

- 1) Excessive speed fluctuation in your cassette recorder.
- 2) Erroneous data recorded on data tape.

2) LOADING a single voice.

This function loads any single voice from within a voice group, and operates basically in the same way as for loading a voice group. Instead of pressing the **LOAD** key, press the **LOAD SINGLE** key.

(1) Make sure the cassette recorder is properly connected and set the tape to the beginning of the voice group that contains the desired voice.

(2) Press the **LOAD SINGLE** key and then the **YES** key and the display will read "from TAPE to BUF single 10 ready?". The DX9 is asking you for the number of the desired voice.

(3) Press the preset key corresponding to the number of the desired voice and the display will respond with the chosen voice number and "ready?".

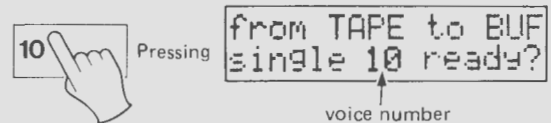

(4) Press the **YES** key and the tape will begin playback. The pilot tone will be heard.

(5) Set the cassette recorder volume control so that the pilot tone is at a comfortable listening level.

(6) The display counts down the voices in the group, and the DX9 PLAY mode is engaged when the desired voice has been loaded. The voice number display shows "0". The loaded voice must then be stored in any preset number according to the STORE instructions on page 17.

● **Let's keep a record of this voice for future reference.**

At the end of this manual you will find a voice data list. Use this list to record the values of every parameter used. Make copies of this list and use them to record the parameters of any new voices you create yourself. This will be useful to restore voices that have been erased, and will serve as an excellent guide for creating new voices.

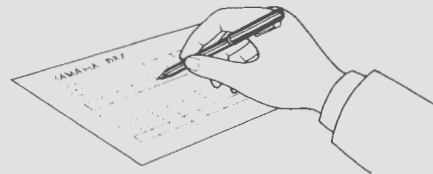

MIDI

MIDI (Musical Instrument Digital Interface)

The MIDI terminal is for external control of electronic musical instruments. Any instrument equipped with a MIDI terminal can be connected using the MIDI cable and used for transmitting data to the instrument.

MIDI can be used for the following types of data transmission and control:

● Real-Time Control

This is used for controlling more than one electronic musical instrument at once using a sequencer to form a musical ensemble. It can also be used to control a second electronic musical instrument via the keyboard of the main instrument.

1. Key pitch ON/OFF, etc.
2. Pitch bend, modulation wheel, sustain switch, etc.
3. Voice number.

● Connecting the MIDI cable

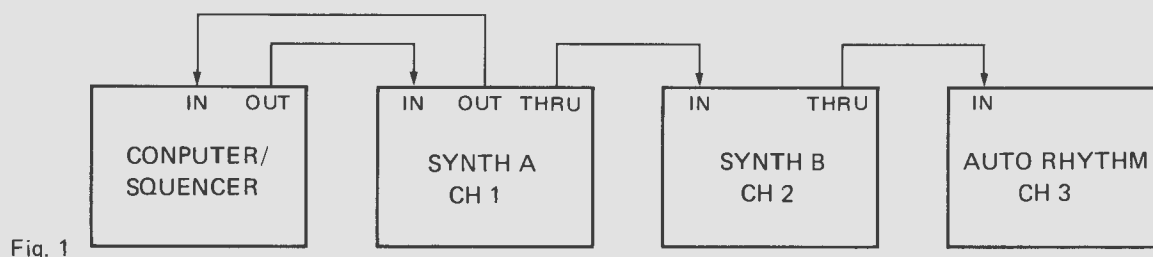

Fig. 1

As can be seen in figure 1, the data output from the sequencer is transmitted via a single MIDI cable and input to synthesizer A, where it is sent to the next instrument to be controlled via the THRU terminal. In this case, the sequencer is outputting multi-channel data. Therefore, the desired channel number on the receiving side must be selected accordingly. Both the sending side and the receiving channel numbers will have to be specified with the system shown in figure 2.

● System Information

Certain types of data can be transferred between certain groups of instruments of the same manufacturer.

The following types of data can be exchanged using the YAMAHA DX9 and/or DX7.

1. Data for one voice or for all voices.
2. The data for a single parameter within a certain voice.
3. The data for a single parameter within the FUNCTIONS.

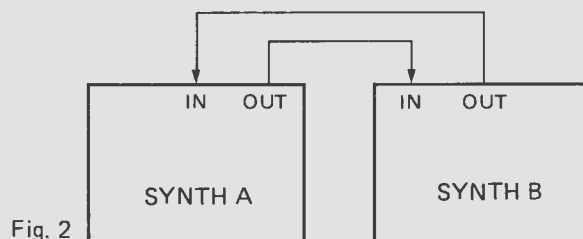
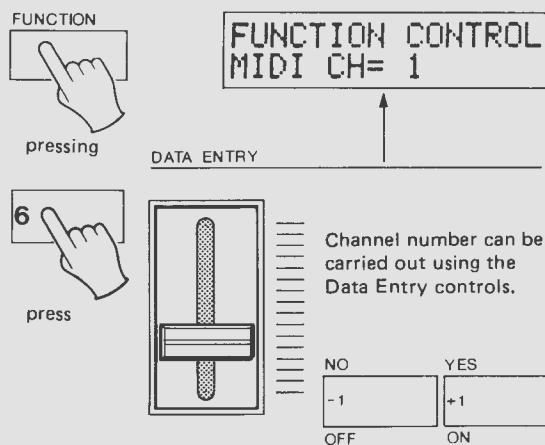

Fig. 2

● Selecting the Receiving Channel

While the unit is in the FUNCTION mode, pressing **[6]** will produce the display shown in the figure. The selection of the MIDI receiving channel number can be carried out using the DATA ENTRY controls. Select system information YES/NO for both the receiver and the transmitter. Pressing **[6]** again will produce the display "SYS INFO UNAVAIL". Press **[ON]** to change this to "AVAIL", and the instrument will enter the system information transmit/receive mode.



Using MIDI.

● Real-Time Control

1. Sequencer Controlled Automatic Performance

With the system shown in figure 1, let us use the DX9 as synthesizer A, and the DX7 as synthesizer B. Specify the DX9 receiving channel as 1, and the DX7 receiving channel as 2. This will enable automatic performance under sequencer control.

2. Remote Control Performance

Hooking up the remote keyboard KX1 to a DX9 as shown in the figure, will enable you to remotely control the DX9 from the KX1 keyboard. In addition, by connecting a DX9 and a DX7, the DX7 can be controlled from the DX9 keyboard. The DX9's send channel number should also be specified as 1.

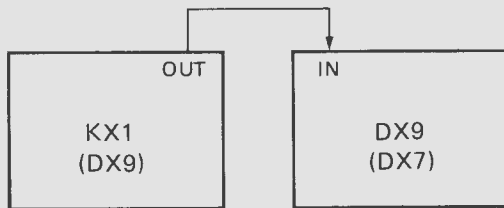

● Transmit System Information

1. Transmit Single Voice Data

When the display appears as shown in the figure, press the voice number key for the voice you wish to transmit. The corresponding voice data will be output from MIDI OUT.

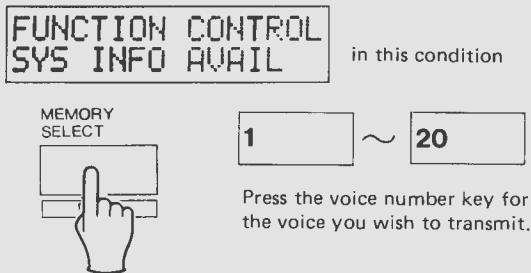

2. Transmit Voice Data for All 20 Voices

Press **6** when the display appears as shown in the upper area of the figure. The display will change to that shown in lower area of the figure. Pressing **ON** will cause the voice data for all 20 voices to be output from MIDI OUT.

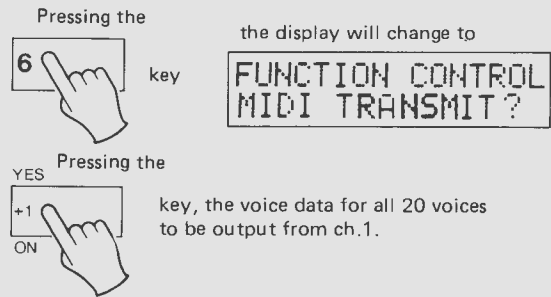

3. Transmit Voice or FUNCTION Parameters

When the display reads "SYS INFO AVAIL", press either **EDIT** or **FUNCTION**. Pressing the key corresponding to the parameter that you wish to transmit will output the data for that parameter from MIDI OUT.

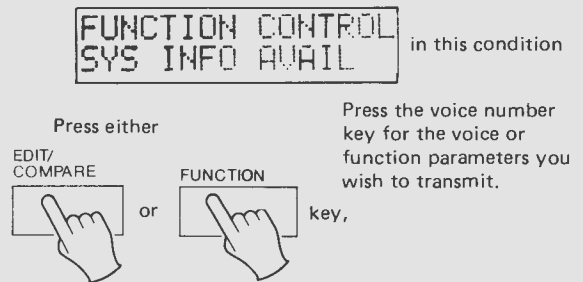

Note: For all of the above, the transmit channel number of the DX9 is 1.

● Receiving System Information

Select the same number for both the receive and the transmit channels. When the display reads "SYS INFO AVAIL", the instrument will be ready to receive system information.

1. Receiving Single Voice Data

After receiving the voice data for a single voice, the voice data will be held in the memory of the buffer and the voice number display shows "0".

2. Receiving the Voice Data for all 20 Voices

Switching the PROTECT off for the memory, will cause the voice data for all 20 voices to be memorized into the internal memory.

3. Receiving Voice or FUNCTION Parameters

When receiving this information, the unit will vary the data for that particular parameter.

LET'S ACTUALLY CREATE A VOICE

EDIT OPERATION

Using the EDIT mode of the DX9, you can modify the pre-programmed voice or even create your own original voices.

1. Modifying a Pre-programmed Voice

- 1) First, select the pre-programmed voice you wish to modify. Select any voice number from 1 to 20.
- 2) Enter the EDIT mode by pressing the **EDIT** key.
- 3) Select the parameters you wish to modify and change their values.

A small dot will appear next to the display voice number when there is a data modification.

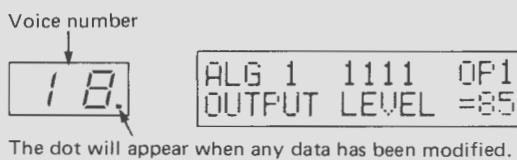

When you wish to hear what the original voice sounded like, press the **EDIT/COMPARE** key once again. The voice number will flash and the sound of the original voice will be reproduced (during this procedure, you can not modify data). Pressing the **EDIT/COMPARE** key will cause the DX9 to revert to the original voice. When you wish to continue your efforts in voice creation, press the **EDIT/COMPARE** key again. In this manner, you can compare your sound with that of the original voice in order to see how your voice is progressing.

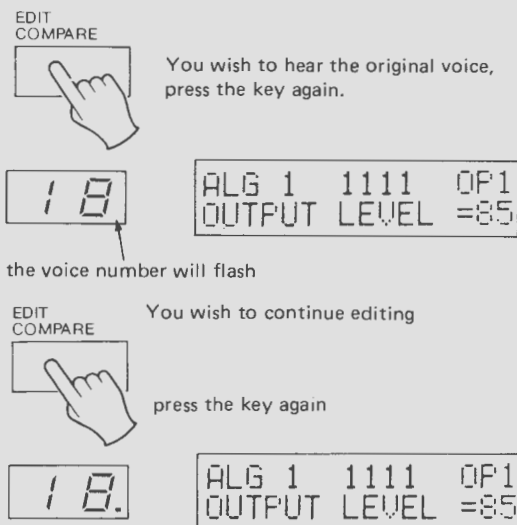

- 4) Store the edited voice in the internal memory. See the STORE/SAVE/LOAD section on page 17, and carry out the save procedures using it as a reference.

2. Creating an Original Voice.

To create an entirely new voice, you can use one of the pre-programmed voices as the "raw material" for modification. However, the feed-back and LFO parameters can complicate the procedure and make things quite difficult. Therefore, it is advisable to use the "basic" voice parameters when beginning voice creation from scratch. We'll create a CLARINET sound to exemplify this procedure.

- 1) Press the **FUNCTION** key to set the DX9 to the FUNCTION mode.

Press **VOICE INIT** key. Next press the **YES** key. The display will then show "ARE YOU SURE?". Pressing the **YES** key once again will cause the voice data to be set to the basic settings, and the DX9 will exit the FUNCTION mode and enter the EDIT mode. It is now ready to create new sounds.

- 2) Selecting the Algorithm.

Choose one algorithm out of the 8 available. For example, we'll select Algorithm 1. Press the **ALGORITHM** key. Set the DATA ENTRY section to 1.

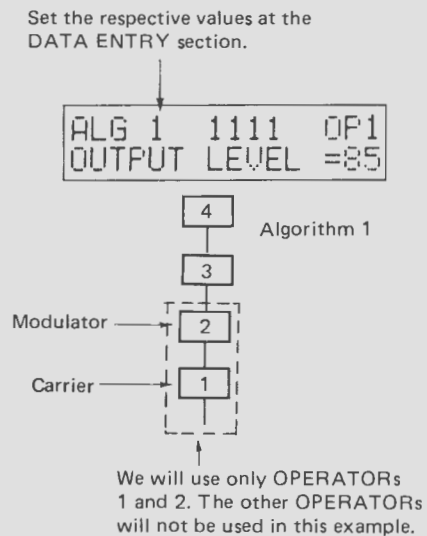

- 3) Disable all OPERATORS that are not immediately necessary.

The carrier parameters should be defined first. The carrier for algorithm 1 is OPERATOR 1. First, set the output level of OPERATOR 1 to any value. Press the OPERATOR **OUTPUT LEVEL** key. Set OPERATOR 1 to 99. Set OPERATOR 2 to 70. The unused OPERATORS 3 and 4 should be set to 0. Pressing the **OPERATOR SELECT** key, select the OPERATORS. Disable all OPERATORS not immediately necessary. Press the **OPERATOR ON-OFF** keys 2 through 4. OPERATORS 2 through 4 are now disabled.

4) Determining the CARRIER FREQUENCY

When attempting to create the sound of a clarinet, the CARRIER versus MODULATOR frequency ratio should be set to 1:2. Press the **FREQUENCY FINE** and **FREQUENCY COARSE** keys, and set the pitch to 1.00.

5) Determining the amount of DETUNE.

In our attempt to create the sound of a clarinet, only OPERATOR 1 will be functioning as a carrier and therefore DETUNE should be set to 0. Press the **DE-TUNE** key. Set the value of "OSC DETUNE" to 0.

6) Setting the ENVELOPE GENERATOR

First, we'll set the ENVELOPE GENERATOR of the carrier. For example, we'll set the parameters to the following values:

Pressing each key in succession will cause the values to advance from 1 to 4.

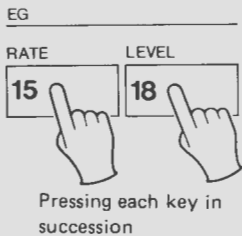
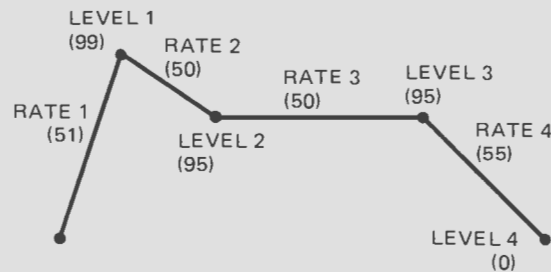

```
ALG 1 1111 OP1
EG RATE 1 =51

ALG 1 1111 OP1
EG LEVEL 1 =99
```

With the DX9 set in this mode, play on the keyboard and listen to the sound produced. The sound produced will be a pure sine wave from the carrier only. Now set the envelope of the carrier for an appropriate sound. Next, we'll set up the modulator data.

7) Using the modulator

In this attempt to create the sound of a clarinet, OPERATOR 2 will be functioning as the sole modulator. Press the **OPERATOR 2** key. OPERATOR 2 is now engaged.

8) Setting the MODULATOR FREQUENCY

Set the MODULATOR FREQUENCY to 2.00 using the **FREQUENCY COARSE** and **FREQUENCY FINE** keys. Set the DETUNE for OPERATOR 2 to 0. Set the "OSC DETUNE" to 0 using the **DE-TUNE** key.

9) Setting the MODULATOR ENVELOPE GENERATOR

To create the sound of a clarinet, the parameters of the modulator's envelope generator should be identical to the parameters of the carrier's envelope generator. This process can be carried out in a few seconds by using the COPY function. Using the COPY function, copy the OPERATOR 1 envelope generator data to OPERATOR 2. Set the display to "OP 1" by pressing the **OPERATOR SELECT** key.

While pressing the **STORE** key, press this key. The display will show the number of the operator that was selected with the **OPERATOR SELECT** key. This signifies that the envelope generator parameters and keyboard scaling parameters of OPERATOR 1 are being copied to OPERATOR 2.

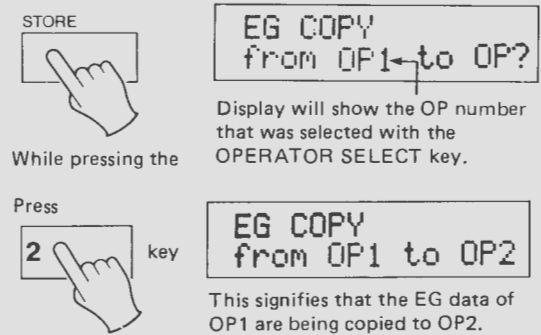

10) Adjusting Tone

At this point, listen to the sound. The sound produced will probably be a little harsh. In this case, lower the OUTPUT LEVEL of OPERATOR 2 by pressing on the **OPERATOR SELECT** key. While pressing on the OPERATOR **OUTPUT LEVEL** key, lower the value of the output level using the DATA ENTRY slide control. With an output level setting of 61, the sound produced will approach that of an actual clarinet. Let's set the output level of OPERATOR 2 to 61. Later on, with more careful control of the envelope generators of OPERATORS 1 and 2, you can tailor the sound more precisely for your requirements.

11) Adding Modulation

Let's add a vibrato effect to the clarinet sound produced. Set the modulation controls so that the MODULATION wheel can be used to add a subtle touch of vibrato.

1. Set the LFO Waveform.
Pressing the **LFO WAVE** key, set the wave form to "TRIANGLE".
2. Set the LFO Speed.
Pressing the **SPEED** key, set the LFO's speed to "28". This will produce a moderately slow vibrato.

-
-
3. Set the LFO DELAY.
Pressing the **[DELAY]** key, set the LFO DELAY to "36". The vibrato effect will begin a few seconds after a key is played.
 4. The modulation controls should be set so that the vibrato effect will be controlled solely by the Modulation wheel. Pressing the **[PMD/AMD]** key, set the "LFO PM DEPTH" and the "LFO AM DEPTH" to "0". The setting for both OPERATORS 1 and 2 should be "0".
 5. Set the MODULATION SENSITIVITY.
Pressing the **[PITCH/AMP]** key, set the "P MOD SENS" to "1". This means that the pitch will be modulated slightly by the LFO. Pressing again the **[PITCH/AMP]** key, set the "A MOD SENS" to "0". The settings for both OPERATORS 1 and 2 should be "0".
 6. Control the Vibrato Effect with the Modulation Wheel.
Pressing the **[FUNCTION]** key, set the DX9 to the FUNCTION mode.
 7. Set the Modulation Wheel RANGE.
Pressing the **[MODULATION WHEEL RANGE]** key, set the RANGE to "33". This produces a slight amount of vibrato.
 8. Turn PITCH ON, AMPLITUDE OFF.
Pressing the **[PITCH]** key, set the PITCH to "ON". This signifies that the modulation wheel controls the LFO modulation of the pitch.
Pressing the **[AMPLITUDE]** key, set the AMPLITUDE to "OFF".
 9. Set the EG (Envelope Generator) BIAS to OFF.
Pressing the **[EG BIAS]** key, set the EG BIAS to "OFF". Now, by manipulating the MODULATION WHEEL, you should be able to control the amount of vibrato on the clarinet while playing.
- 12) Saving Your Original Voice In Memory**
Refer to the STORE/SAVE/LOAD on page 17.

LFO BLOCKDIAGRAM

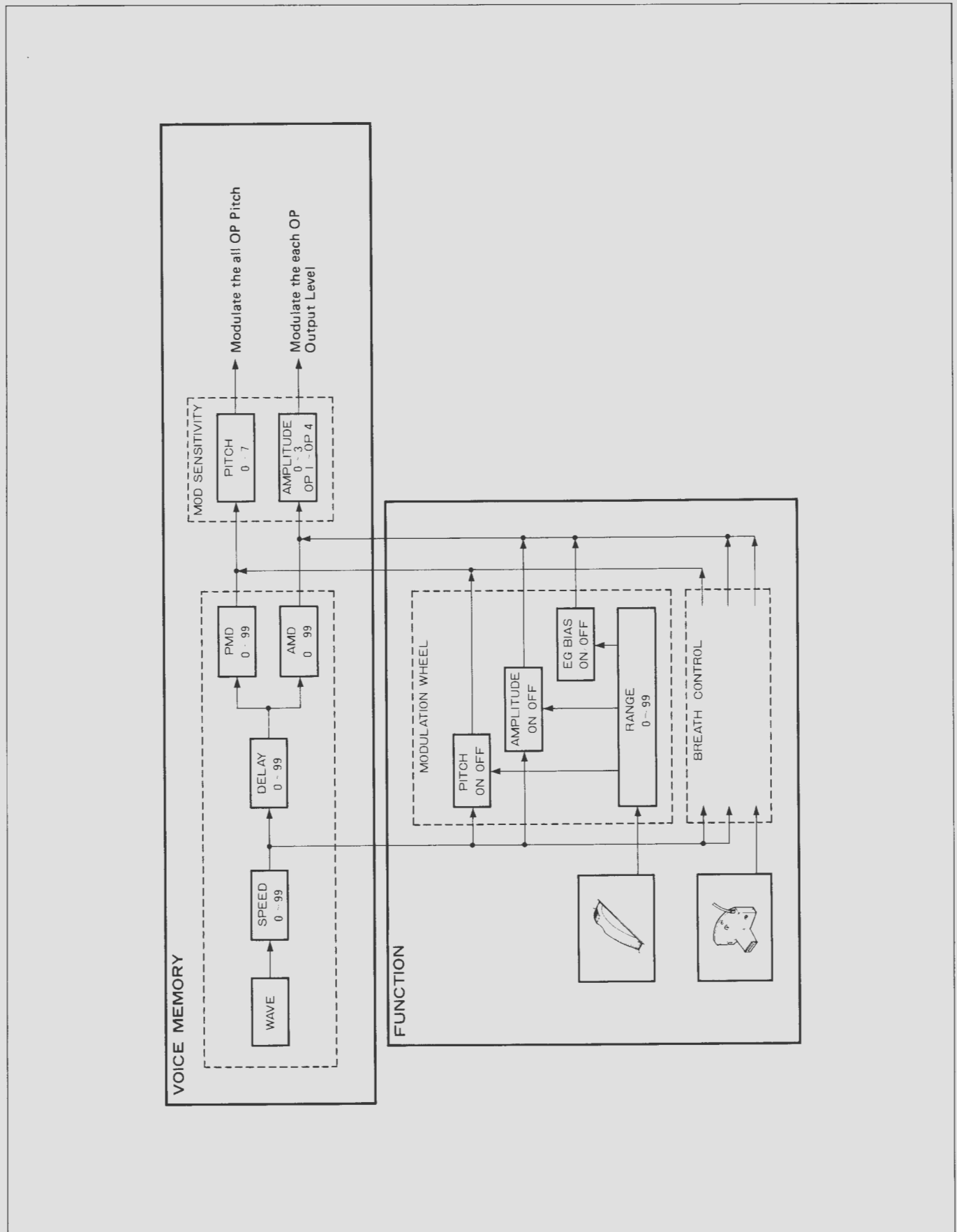

SPECIFICATIONS

Keyboard	61 keys, C ₁ ~ C ₆
Sound Source	FM Tone Generator: 4 operators, 8 algorithms
Simultaneous Output Notes	POLY mode: 16 notes MONO mode: 1 note
Internal RAM Memory	20 Bank (20 Memory)
External Memory	Cassette Interface
Mode Selectors	STORE, EDIT/COMPARE, PLAY-MEMORY SELECT, FUNCTION
Controls	VOLUME, DATA ENTRY [lever, switch: YES (ON)/ NO (OFF)], PITCH WHEEL, MODULATION WHEEL, OPERATOR ON-OFF, EG COPY, OPERATOR SELECT
Voice Parameters	
ALGORITHM	1 ~ 8
FEED BACK	0 ~ 7
LFO WAVE	 S/H
SPEED	0 ~ 99
DELAY	0 ~ 99
PITCH MODULATION DEPTH	0 ~ 99
AMPLITUDE MODULA- TION DEPTH	0 ~ 99
PITCH MODULATION SENSITIVITY	0 ~ 7
AMPLITUDE MODULA- TION SENSITIVITY	0 ~ 3
OSCILLATOR FREQUENCY COARSE	0.5 ~ 31
FREQUENCY FINE	(FREQ. COARSE) x 1.0 ~ 1.99
DETUNE	-7 ~ +7
KEY SYNC	ON/OFF
EG RATE (1 ~ 4)	0 ~ 99
LEVEL (1 ~ 4)	0 ~ 99
KEYBOARD SCALING RATE	0 ~ 7
LEVEL	0 ~ 99
OPERATOR OUTPUT LEVEL	0 ~ 99
KEY TRANSPOSE	±1 octave

Function Parameters	
MASTER TUNE ADJ	±75 cents
POLY/MONO	
PITCH BEND RANGE	0 ~ 12
PORTAMENTO MODE	FULL TIME/FINGERED
TIME	0 ~ 99
MODULATION WHEEL RANGE	0 ~ 99
PITCH	ON/OFF
AMPLITUDE	ON/OFF
EG BIAS	ON/OFF
BREATH CONTROL RANGE	0 ~ 99
PITCH	ON/OFF
AMPLITUDE	ON/OFF
EG BIAS	ON/OFF
CASSETTE	SAVE/VERIFY, LOAD, LOAD SINGLE, REMOTE
EDIT RECALL	
VOICE INITIALIZE	
BATTERY CHECK	
MEMORY PROTECT	
MIDI CHANNEL	1 ~ 16
SYSTEM INFORMA- TION	AVAILABLE/UNAVAILABLE
MIDI TRANSMIT	
Connecting Terminal	OUTPUT (600 Ω: UNBALANCED) PHONES (8-150 Ω)
Control Terminal	FOOT SWITCH (SUSTAIN, PORTAMENTO), FOOT CONTROL (VOLUME), BREATH CONTROL, MIDI (IN, OUT, THRU), CASSETTE INTERFACE (IN, OUT, REMOTE)
Others	LCD DISPLAY
Power Consumption	35 W
Dimensions (W x H x D)	101.8 x 10.2 x 32.9 cm (40" x 4" x 13")
Weight	12.4 kg (27.4 lbs.)
Accessories	Voice Data Cassette Tape (120 voices), Cassette Interface Cable, Music Stand

* Specifications and design are subject to change without notice for improvement.



VOICE DATA LIST

VOICE NAME : _____
 DATE : _____
 VOICE NUMBER : _____ Group, No.
 PROGRAMMER : _____

OP	4	3	2	1	A	F	WAVE	SPEED	DELAY	PMD	AMD	PITCH	AMP
1	2	3	4	5	6	7	8	9	10				

POLY/MONO	PITCH BEND RANGE	PORTAMENTO	
		MODE	TIME

OP
4
3
2
1

OP	4	3	2	1	D	S	RATE	EG	LEVEL	RATE	LEVEL	KEYBOARD SCALING	OPERATOR	OUTPUT LEVEL	KEY TRANS-POSE
11	12	13	14	15	16	17	18	19	20						

RANGE	PITCH	AMPLITUDE	EG BIAS	RANGE	PITCH	AMPLITUDE	EG BIAS

FCC CERTIFICATION (USA)

While the following statements are provided to comply with FCC Regulations in the United States, the corrective measures listed are applicable worldwide.

This series of Yamaha combo Keyboards use frequencies that appear in the radio frequency range and if installed in the immediate proximity of some types of audio or video devices (within three meters), interference may occur.

This series of Yamaha Combo Keyboards has been type tested and found to comply with the specifications set for a class B computing device in accordance with those specifications listed in subpart J of part 15 of the FCC rules. These rules are designed to provide a reasonable measure of protection against such interference. However, this does not guarantee that interference will not occur. If your Combo Keyboards should be suspected of causing interference with other electronic devices, verification can be made by turning your Combo Keyboards off and on. If the interference continues when your Keyboard is off, the Keyboard is not the source of the interference. If your Keyboard does appear to be the source of the interference, you should try to correct the situation by using one or more of the following measures:

Relocate either the Keyboard or the electronic device that is being affected by the interference.

Utilize power outlets for the Combo Keyboard and the device being affected that are on different branch (circuit breaker or fuse) circuits, or install a/c line filters.

In the case of radio — T.V. interference, relocate the antenna or, if the antenna lead-in is 300 ohm ribbon lead, change the lead-in to co-axial type cable.

If these corrective measures do not produce satisfactory results, please contact your franchised Yamaha Combo Keyboard dealer for suggestions and/or corrective measures. If you can not locate a franchised Yamaha Combo Keyboard dealer in your general area contact the Combo Service Department, Yamaha International, 6600 Orangethorpe Ave., Buena Park, CA 90620.

If for any reason, you should need additional information relating to radio or T.V. interference, you may find a booklet prepared by the Federal Communications Commission helpful: "How to Identify and Resolve Radio — T.V. Interference Problems". This booklet is available from the U.S. Government printing office, Washington D.C. 20402 — Stock #004-000-00345.

SINCE 1887



YAMAHA

NIPPON GAKKI CO., LTD. HAMAMATSU, JAPAN

OMD-73

83125  Printed in Japan